

Advanced engineering helps ensure extended compressor life

1 Ful-Vane® compressors are equipped with a fixed bearing at the coupling end of the shaft, and a floating bearing at the closed end. The fixed bearing allows the compressor shaft to carry greater horsepower side loading when a V-belt drive arrangement is used. Also, this bearing combination allows for thermal expansion of the rotor, yet maintains clearances during operation for high efficiency.

2 Our new B-3000™ blade material is lighter, stronger, longer-wearing and non-hygroscopic. As a result, these vanes last longer and save you money on parts and downtime.

3 Packing is the standard seal arrangement on Ful-Vane air compressors; however, for specialized applications a mechanical seal is also available.

4 The rotor is made from a single-piece of ductile iron that can withstand higher stress values. As the vane slots wear over time, they can be re-slotted multiple times to increase longevity. Thicker vanes are also available.

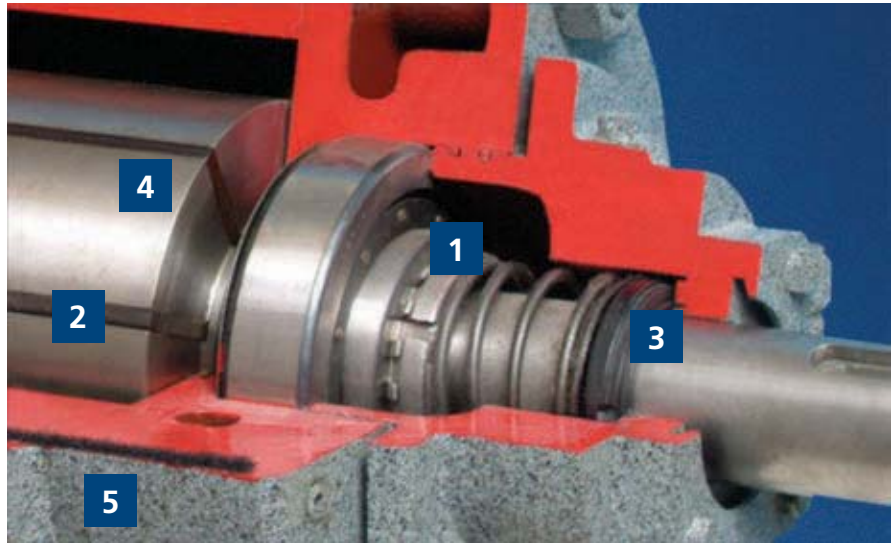

5 The cast iron cylinder assembly is manufactured for very dusty, dirty, and highly-corrosive environments. The cylinder can be re-bored multiple times for longer life. Our exclusive undercut bore is available for increased volumetric efficiency and ease of maintenance. Circular bore compressors are available for operation at higher speeds and capacities.



B-3000™ Blades

- Blades last 3 to 5 times longer than phenolic or Kevlar blades
- Reduce oil consumption by up to 50%
- Extend overall life of the compressor
- Reduced maintenance costs
- Guaranteed to never cause a catastrophic cylinder failure

